

Published: 11/25/66

Identification

Major Module Port Assignment
Harlow Frick, J. H. Saltzer

Purpose

This section describes a standard way to connect cables between major modules at 645 Multics installations. Also, standard nomenclature and conventions are introduced for discussing port assignments. The standard connections listed here are based on three considerations:

1. Hardware restrictions
2. Software restrictions
3. Consistency, to simplify reconfiguration

The connections described in this section apply to the maximum configuration in use at a given installation and include all physical equipment available at that installation. These cable connections are not changed when the system is electrically reconfigured for system testing or hardware malfunction.

System Controllers

Each System Controller has a maximum of eight ports to which active modules may be connected. These ports are numbered 0, 1, 2, etc., in decreasing order of priority. Starting with port 0, active modules are attached to System Controller ports in the following order:

EMM #1	}	all EMM's
EMM #2		
etc.		
GIOC #1	}	all GIOC's
GIOC #2		
etc.		
CPU #1	}	all CPU's
CPU #2		
etc.		

This pattern is repeated identically for every System Controller.

Active Modules

Each active module has a maximum of eight ports, lettered A, B, C, etc., to which System Controllers may be connected. All active modules are connected to system controllers identically, as follows: port A of each active module is connected to System Controller 1; port B to System

Controller 2, etc., up to the maximum number of System Controllers at the installation.

Special Processor Port Assignment

(This paragraph to be deleted when Prototype System Clock is no longer used with 645 systems.)

Whenever a system contains one or more prototype system clocks, each system clock appears to reside in its own System Controller; no core memory exists in this special clock controller. A system using prototype system clocks may not have more than two processors, since the special clock controllers have only two ports. We assume here that a system does not contain more than two prototype clocks. The eight processor ports are assigned as in table 1 when prototype clocks are used. If prototype clocks are not used, processor ports are assigned exactly the same as all other active modules.

Example

Figure one illustrates the cable assignment for a system containing four system controllers, one EMM, two processors, and two prototype system clocks.

Processor Port	Connects to		
	2-controller system	4-controller system	6-controller system
A	Clock 1	Clock 1	Clock 1
B	Clock 2	Clock 2	Clock 2
C	(unused)	(unused)	controller 5
D	(unused)	(unused)	controller 6
E	controller 1	controller 1	controller 1
F	controller 2	controller 2	controller 2
G	(unused)	controller 3	controller 3
H	(unused)	controller 4	controller 4

Table I: Processor Port connection when prototype clocks are used.

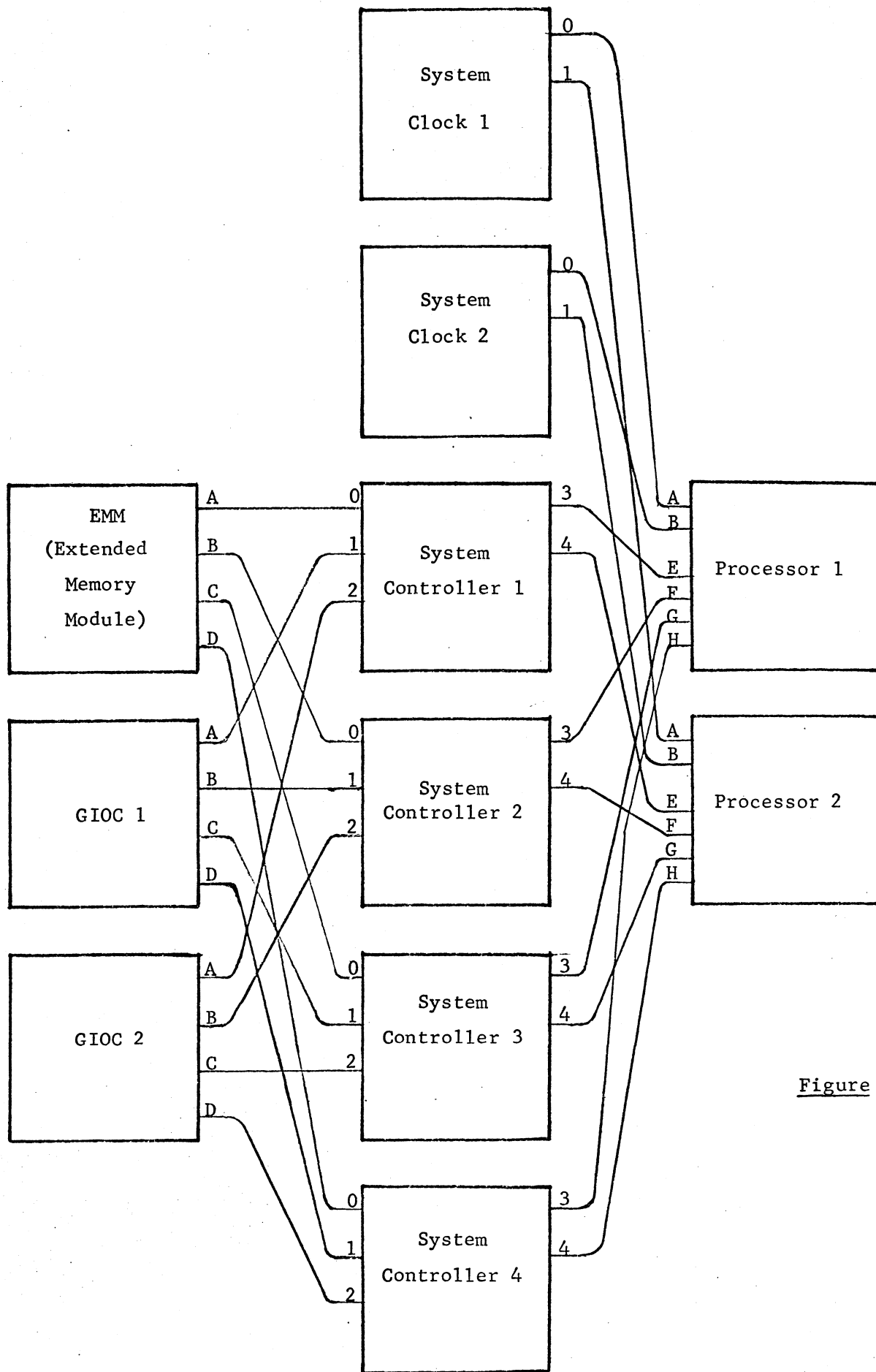

Figure 1.