

#####

#####

#####

Number: MTB-486

Title: Operator Console Support Changes for MR9.0

Author: M. R. Jordan
(MJordan.Multics @ System-M)
(MJordan.Multics @ MIT-Multics)

S. D. Sprague
(Sprague.Multics @ System-M)
(Sprague.Multics @ MIT-Multics)

Date: 31 December 1980

Revision: 0

Multics Project internal working documentation. Not to be reproduced without the consent of the author or the director of Multics System Development.

INTRODUCTION

This MTB describes the changes to be made to Multics to support the Low Cost Console (LCC).

This support is required as part of the DPS 8/70M project. It is intended to satisfy the requirements for the Remote Maintenance Interface (RMI) for the DPS 8/70M set forth in the RMI PFS (#58020576) and the Distributed Maintenance Services (DMS) Global PFS (#58020598).

HARDWARE CONFIGURATIONS

This new hardware is a microprocessor controlled IOM channel which allows standard RS-232 connections to a VIP or ROSY to be used as a console.

The firmware is contained in on-board PROMs and can provide either single or dual logical channel operation. In either case there are three RS-232 connections which are called the local, slave, and remote ports. The local port is connected to either a VIP or ROSY for use as the system console. In the case where the local console device is a VIP, the slave port can be connected to an output only ROSY printer for hard copy. The remote connection can be connected to a modem for remote access. In all cases the remote port must be enabled by the operator via the local port.

The functions that were performed in the past using the special keys and buttons on the console are mapped into ASCII character sequences. These include: Request (CR), EOM (CR), Operator Error (^X), Attention Reset (CLR or CR), Boot (ESC-^B), and Initialize (ESC-^I). Provision for the audible alarm present on previous consoles have been made using the bells of the terminals on the local and slave ports, and is therefore of lower volume. The 'input' light that existed on previous consoles is not present.

Single Channel Operation

When configured in the single channel mode, the LCC is compatible, as far as software interfaces, with the EMC.

This mode of operation is only intended for Level 68 and DPS systems where the RMI is not required. In this mode the LCC functions only as a console device.

Dual Channel Operation

When configured in dual channel mode, the LCC appears to be two distinct consoles on two different logical channels. The first of these two logical channels is used for the local and slave connections and the second for the remote connection.

This mode of operation is intended primarily for Distributed Maintenance Services (DMS), Phase II support. In the DMS environment the Diagnostic Processor Unit (DPU) will be connected to the remote channel. In addition, the DPU will have connections to the Dynamic Maintenance Panels (DMPs) of the CPUs, IOMs, and SCUs in the configuration as well as a modem for remote connections. See Figure 1 below for an example of a typical systems connections.

The end result of these connections is that a specialist in the Technical Assistance Center (TAC) will be able to perform remote functions required for DMS via the remote connection to the DPU. These functions include: online software installation and maintenance, online hardware problem diagnosis and isolation, and support of hardware and bootload problems when Multics is not operational. This last function is supported by the console channel itself and requires no software (since, of course, there is no software in execution in these situations). This leaves the online support.

Since remote, decentralized online hardware and software maintenance has always been a basic building block of Multics, if we can simply allow login over this remote console channel we can provide online capabilities needed. This is, in fact, the plan.

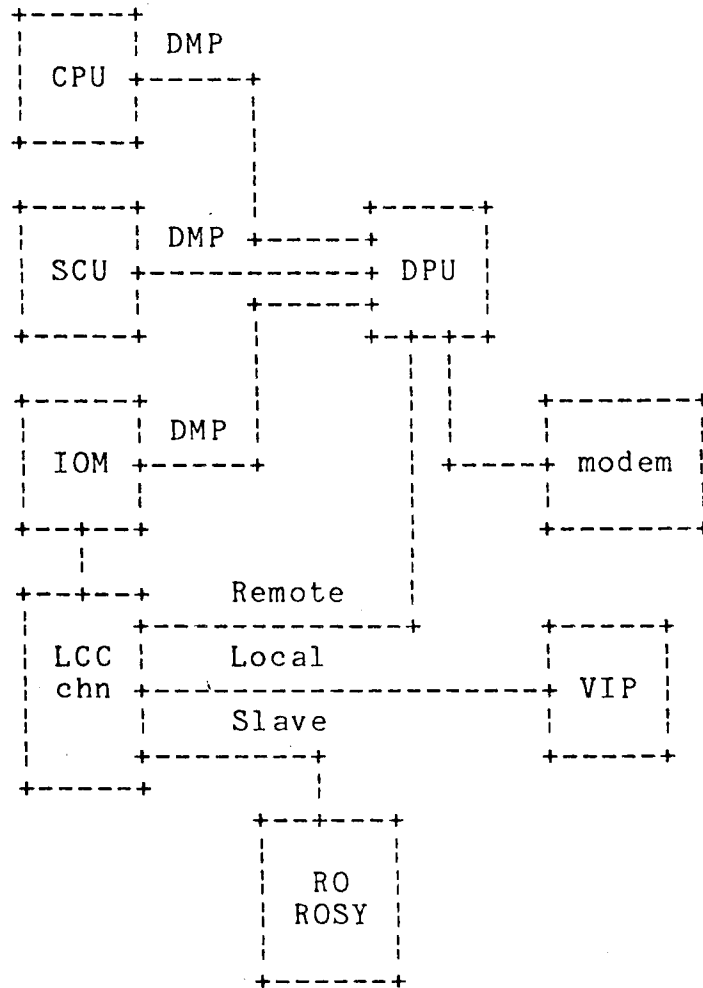

Figure 1. Typical DPU connection.

SOFTWARE MODIFICATIONS

The software changes involved in the support of this new product fall into three categories: general support of the new console device, input prompting, and the required login capability for the RMI.

General Support

The general support changes include modifications to RCP (actually `rcp_init.pl1`) to support the new console model and to allow configuration of multiple consoles. This later change is required to allow the dual channel LCC, or in some cases multiple LCCs, to be described in the config deck. The change will allow console names to be OPC or OPCx, where x is any alphanumeric

character.

Since it will be possible to specify more than one console device in the config deck, a mechanism for determining which console is to be used for system operation is needed. This will be accomplished by using the console which BOS found at bootload time. BOS will place the IOM and channel numbers in the flagbox and Multics console initialization will use these to find the console. In the case where there is no console configured on that channel, Multics initialization will fail as it does today when there is no console configured.

Prompting

The changes for input prompting must be made to both BOS and Multics. This prompting will replace the input light of the previous consoles in providing some form of visual feedback for the operator. Without this visual feedback the operator has no idea whether the console is in input mode or output mode (i.e., whether CR is REQUEST or EOM). This prompting will be enabled automatically for the LCC and will also be available optionally for other console devices.

BOS Prompting

BOS will be modified to provide an optional prompt on input. This will be enabled/disabled via the PROMPT command which will take either ON or OFF as an argument. The default will be PROMPT ON for the LCC and PROMPT OFF for all other console devices.

The prompt string will be the name of the BOS command followed by "->" with the following exceptions: at BOS command level the prompt will be the string "BOS->"; in EDIT input mode the prompt will be "INPUT->."

As part of the PROMPT work READY and QUIET will be changed. The BOS ready message will now be controlled independent of the quiet mode. The READY command will control the printing of the BOS ready message and the QUIET command will control printing of output other than ready messages and prompts.

Multics Prompting

The console interface software, ocdem.pl1 and oc_data_init.cds, must change to allow prompting. If prompting is enabled, the console software will build its channel program to include the prompt whenever input is performed. If prompting

is disabled there will be no difference from current operation.

Again, like BOS, prompting will be enabled by default for LCC devices, but disabled for other consoles. A simple command, `oc_prompt`, will be provided to override these defaults. The prompt string can be specified on the config card for the console device, thus allowing different prompts for different console devices, or it can be specified via the `oc_prompt` command. If no prompt string is specified on the config card or via `oc_prompt` and prompting is enabled a default prompt string of "" will be used. The actual prompt seen on the console will be a catenation of the prompt string and the string "->."

A complete command description for `oc_prompt` can be found in appendix A.

In addition to this prompting change, a line length specification will be added to the PRPH OPC card. The addition of the line length is in response to the Software Change Proposal (SCP) from FORD to support the full line length of the EMC with a full width ROSY printer. The new PRPH OPC card format is described in appendix A.

Note that this card is not being changed to add a `<nchan>` field as in the case of tape or disk subsystems because this is not a subsystem in the same sense. Each logical channel of the LCC is a separate console to the software.

Login Capability

To support the DPU connection for remote maintenance, Multics must provide the capability to login over the remote channel of the dual channel LCC. This will be accomplished by a command that can attach up to 8 consoles and 8 pseudo TTY (STY) channels. This command, `console_server.pl1`, then routes I/O requests as necessary to allow the logical connection of the console to the STY channel (see Figure 2 below for a diagram of the connections). This command will execute in a daemon process that will be created for this purpose. This daemon could also remove some of the miscellaneous load from the initializer (e.g., `poll_mpc`, `poll_mos_memory`, etc.). In fact this process has existed for several months on the CISL development system as `Pollster.Daemon` and deals with all MPC polling and `console_server` load.

This approach not only allows login, but also allows the use of these consoles as message coordinator consoles, or anything else that can be accomplished via STY channels. Note that this would allow sites with multiple consoles to use the backup console as a message coordinator console.

This command also implements an optional prompting feature so that when the return key on the remote console is depressed to begin input, a prompt string will be output before the input is accepted.

A complete command description for console_server can be found in appendix A.

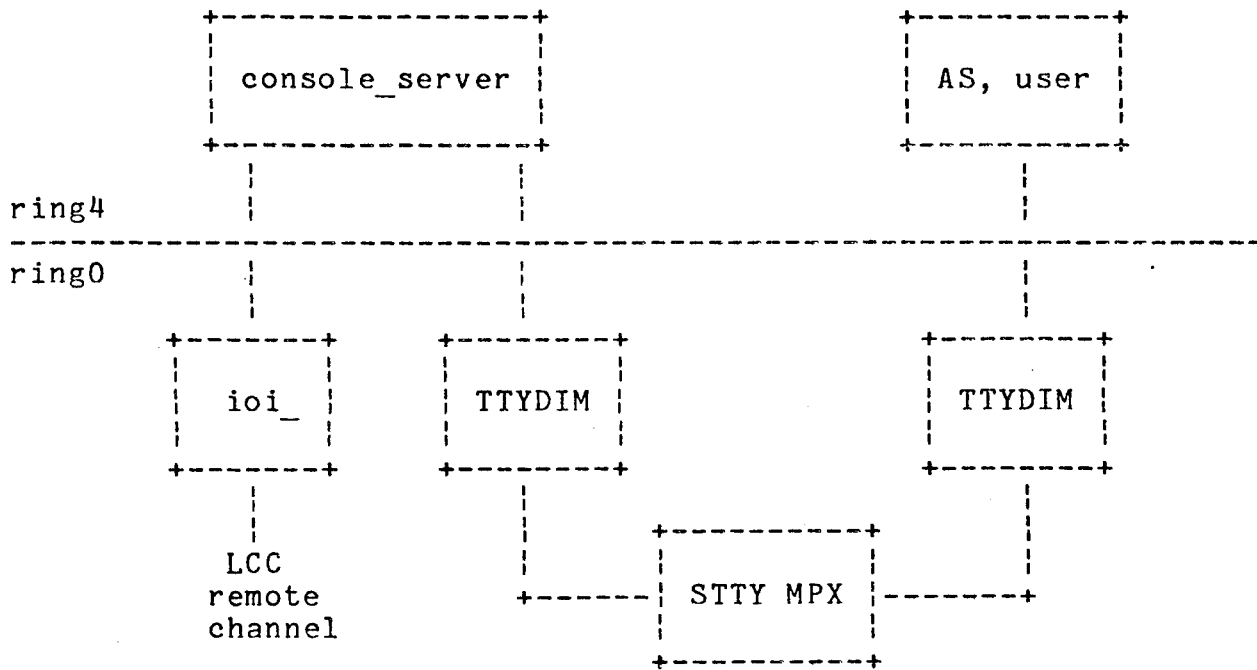

Figure 2. Console server logical connections.

Appendix A

This appendix contains documentation changes for MR9.0 console support. There may be other changes submitted with the Multics Change Request (MCR).

console_server

console_server

Name: console_server

This command allows the connection of up to 8 console devices as either login or message coordinator consoles.

Usage: console_server opc1 sty1 {... opc8 sty8} {-control_arg}

where:

1. opc_n
is the name of a console. This console name must be configured in the config deck.
2. sty_n
is the name of a pseudo TTY (STY) channel. This channel must be defined in the CDT.
3. -control_arg
can be chosen from the following:
 - prompt STR
sets the prompt string for all attached consoles to STR.

Example

Assuming the following STY channel definition in the CDT:

```
-----
console_server
-----
```

```
-----
console_server
-----
```

```
name:          sty;
service:       multiplexer;
multiplexor_type: sty;

Terminal_type: STY;
Attributes:    hardwired;

name:          sty.slogin_01;
service:       login;
terminal_type: VIP7200;

name:          sty.ulongin_01
service:       autocall;

name:          sty.smc_01;
service:       mc;
terminal_type: VIP7200;

name:          sty.umc_01;
service:       autocall;
```

The following command line would make OPCA a login device and OPCB a message coordinator device each with a prompt string of "->":

```
console_server opca sty.ulongin_01 opcb sty.umc_01 -prompt ->
```

Notes

This command manages the I/O to/from the consoles and STY channels to make each console appear as if it were a communications device.

oc_prompt

oc_prompt

Name: oc_prompt

This command allows the system administrator or operator to control prompting on the specified console device.

Usage: oc_prompt on-or-off {-control_arg}

where:

1. on-or-off

is either the string "on" or the string "off" to either enable or disable prompting on the operators console.

2. -control_arg

can be chosen from the following:

-prompt STR

sets the prompt string for the specified console to STR.

Note

This command can only be used to control prompting on the primary console (i.e., the console found by BOS at bootload).

New PRPH OPC config card format.

```
PRPH OPCx <iom> <chan> <model> [<%fill> [<line-length> [<prompt>]]]
```

<iom>

is the IOM to which this device is attached.

<chan>

is the IOM channel to which this device is attached.

<model>

is the model number of this device. Valid model numbers are: 8030, 8031, 6001, 6004, 6002, 6005, 6601. The model designators IBM, EMC, and SCC will be retained for one release for compatability. See the table below for more details.

<%fill>

is the percentage of the console buffer to be used for system error messages.

<line-length>

is the output line length of the device. The default is 80.

<prompt>

is the prompt string. This string will be catenated with the string "->" and output as a prompt when console input is performed. The default is "".

Console	model #	model
CO8030	8030	IBM
CO8031	8031	IBM
CSU6001	6001	EMC
CSU6002	6002	SCC
CSU6004	6004	EMC
CSU6005	6005	SCC
CSU6601	6601	LCC